

PDF hosted at the Radboud Repository of the Radboud University Nijmegen

The following full text is a publisher's version.

For additional information about this publication click this link.

<http://hdl.handle.net/2066/36615>

Please be advised that this information was generated on 2021-01-18 and may be subject to change.

The suitability of Tedlar bags for breath sampling in medical diagnostic research

Marco M L Steeghs, Simona M Cristescu and Frans J M Harren

Life Science Trace Gas Facility, Molecular and Laser Physics, Institute for Molecules and Materials, Radboud University, Nijmegen, The Netherlands

E-mail: m.steeghs@science.ru.nl

Received 28 June 2006, accepted for publication 31 October 2006

Published DD MMM 2006

Online at stacks.iop.org/PM/27/1

Abstract

Tedlar bags are tested for their suitability for breath sampling for medical diagnostic purposes. Proton-transfer reaction-mass spectrometry was used to monitor the changes in composition of various mixtures contained in custom-made black-layered Tedlar bags. Characteristic ions at m/z 88 and 95 amu reflect considerable pollution from the bag material. The pollutant found on m/z 88 amu is most probably *N,N*-dimethylacetamide, a latent solvent used in the production of Tedlar film. Gas composition losses during filling were found to range from 5 to 47%, depending on the compound. Once stored, the half-lives of methanol, acetaldehyde, acetone, isoprene, benzene, toluene and styrene were estimated between 5 and 13 days. Losses from breath samples (52 h after filling) were found to be less than 10%. No observable decrease was found for ethylene over 3 days, using laser-based photoacoustic detection. For the use of Tedlar bags, a standardized protocol is advised, where the time point of analysis is fixed for all samples and should be kept as close as possible to the time of sampling.

Keywords: PTR-MS, breath analysis, Tedlar bags, VOCs

1. Introduction

The study of biological processes via the emission of volatile organic compounds (VOCs) is a widely used and accepted method in Life Sciences, including different fields of biology (Boschetti *et al* 1999, Phillips *et al* 1999, Harren *et al* 1999, Woltering *et al* 1989, Steeghs *et al* 2004, Holzinger *et al* 2000), environmental monitoring (Hewitt *et al* 2003, Warneke *et al* 1996) and medical diagnostics (Phillips 1992, Berkelmans *et al* 2003, Jordan *et al* 1995, Karl *et al* 2001, Lechner *et al* 2005, Dannecker *et al* 1981, Steeghs *et al* 2006). Gas analysis is also becoming an important tool in control of industrial processes such as combustion and

plasma diagnostics, investigation of engines or automobile exhaust measurements or headspace analysis during food production (Werle 2003, Lindinger 2005, Jobson 2005). Several publications have shown the diagnostic potential of relatively new, advanced techniques. These include gas chromatography–mass spectrometry (GC–MS) (Phillips and Greenberg 1991), selected ion flow tube-mass spectrometry (SIFT-MS) (Wang *et al* 2004, Davies *et al* 2001) and proton transfer reaction-mass spectrometry (PTR-MS) (Lindinger *et al* 1998a, Prazeller *et al* 1998, Critchley *et al* 2004). The latter two techniques are very promising in breath analysis and fast diagnostics, since they combine on-line measurement capacity with non-invasive, sensitive and multi-component detection of VOCs.

It is not always possible to bring the gas emission source of interest and the gas detection system together. In such cases, the gas sample under analysis needs to be stored in a container and transported to the laboratory. For this, several methods are used, including canisters, cold trapping, adsorbing agents and Teflon and Tedlar bags. These containers should be easy to operate, easy to handle and be able to store a sample for a prolonged period of time. Costs, re-usability, durability, size and versatility are other important issues when choosing a sample holder. Adsorbing agents like Tenax are compound specific, whereas canisters have the disadvantage that they need to be evacuated before sampling, making them inapplicable to breath measurement. Teflon bags are relatively expensive and fragile, making them difficult to be re-used. Here, as an alternative to these widely used methods we have investigated the use of Tedlar bags for the sampling of breath from patients and healthy volunteers.

Tedlar bags have been used previously by Nielsen and co-workers (Nielsen 2002), who have measured nine volatile sulphur compounds from biogas-production plants and reported no detectable losses over a period of 20 h. Only water was found to permeate through the walls until the relative humidity inside reached ambient air values. Sulyok *et al* (Sulyok 2001) observed a 90% recovery rate of sulphuric compounds after 1 week of containment for clear layered Tedlar bags, but found significantly lower recovery rates for black-layered bags. They assumed the losses to be due to uncontrolled adsorption to the carbon-filled black layer. Lau and co-workers (Lau 1989) reported half-lives of six sulphur gases ranging from 0.02 days to 100 days. For acetone, a significant decrease after the first 6 h was found, using standard Tedlar bags (Deng 2004). The same result has been obtained for isoprene levels (Hyspler 2000). N-hexene, p-xylene and 1-propanol were stable for at least 30 min (Myung 1997).

Groves *et al* (Groves and Zellers 1996) studied the significance of water content in the sampled air for the stability of methanol, acetone, 2-butanone, m-xylene, trichloroethane and perchloroethylene. They spiked the bags already containing the sampled air with water to supersaturation to invoke condensation in the bag. Significant differences between wet and dry samples were only found for methanol, acetone and 2-butanone. However, the relative humidity needed to induce this difference was about three times higher than the humidity inside the bag expected from breath (Groves and Zellers 1996). Only methanol was slightly affected at breath humidity levels.

These studies mostly used transparent Tedlar bags and focused on isolated compounds or a complex of several sulphur compounds. It is not clear how this can be translated to breath samples and to black-layered Tedlar bags. To our knowledge, the storage capabilities of these bags for most breath VOCs have not been tested. Here, we test the changes in gas composition of breath and controlled mixtures during storage in black-layered Tedlar bags. PTR-MS, of which the potential for breath measurements was shown before (Jordan *et al* 1995, Karl *et al* 2001, Lechner *et al* 2005), was used for the analysis of more complex mixtures, including breath, while photoacoustic spectroscopy was used to monitor the behaviour of ethylene (Harren and Reuss 1997, Harren *et al* 1999). The contents of bags with several

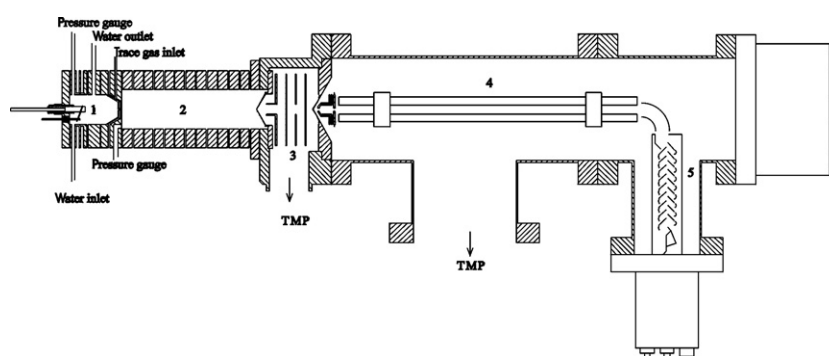

Figure 1. Schematic view of the PTR-MS instrument. (1) is the hollow cathode ion source, (2) the drift tube, (3) the transition chamber, (4) the detection chamber containing the quadrupole and the secondary electron multiplier (5).

different mixtures were analysed and compared at several instances between 4 and 250 h after filling.

2. Materials and methods

2.1. Instrumentation

The proton transfer reaction–mass spectrometer (PTR-MS) used for this work is analogous to that described in Lindinger *et al* (1998b) (figure 1). A detailed description of the home-built system can be found in Boamfa *et al* (2004) and Steeghs *et al* (2006). The working principles of PTR-MS have been given in detail elsewhere (Lindinger *et al* 1998b, Boamfa *et al* 2004, De Gouw *et al* 2003). Therefore, only a brief description is given here.

The instrument consists of four parts: an ion source where H_3O^+ ions are produced, a drift tube section, a separately pumped transition chamber and an ion detection section containing a quadrupole mass spectrometer and a secondary electron multiplier. In the drift tube, the trace gases from the sample gas are ionized by proton-transfer reactions with H_3O^+ ions:



where k is the reaction rate constant, usually close to or equal to the collision rate constant. This reaction only takes place when the proton affinity (PA) of the trace compound R is higher than that of water ($166.5 \text{ kcal mol}^{-1} = 7.16 \text{ eV/molecule}$). A major advantage of using H_3O^+ as the reagent ion is that the PA of water is higher than the PA of the normal constituents of air (cf N_2 , O_2 , CO_2 , CH_4 , CO , NO , Ar) and that most of the typical organic compounds are ionized by the proton-transfer (PT) reaction, since their PA are in the range between 7 and 9 eV. The reaction rate can be measured or calculated and is known for many of the PT reactions of interest (<http://Webbook.Nist.Gov/Chemistry/>, Lindinger *et al* (1998b)). Since the excess energy of the reaction is low, it results in only one or two characteristic ions per neutral molecule. For some molecular groups dissociation can occur to form one or two fragments of significant intensity (e.g. alcohols can split off a water molecule, which results in a fragment ion at molecular mass minus 17). Due to this soft-ionization the matrix of signals is less complicated than with other mass spectrometry techniques. One disadvantage of the technique is that it does not provide positive identification of the compounds monitored (Steeghs *et al* 2004).

Ethylene, a well-known indicator for lipid peroxidation (Kneepkens *et al* 1994) was measured using laser-based photoacoustic detection, as described in Harren and co-workers (Harren *et al* 1999, Harren and Reuss 1997). Briefly, the infrared laser is tuned to a wavelength where the gas under investigation has a high absorption coefficient. By modulating the intensity of the laser light, a periodic heating of the sample gas is caused. This results in pressure variations inside the sample cell of the same frequency as the laser intensity modulation. By carefully choosing the modulation period, an acoustic wave is created inside the closed sample cell, which is detected with a microphone. The amplitude of the acoustic wave is directly proportional to the laser intensity and to the concentration of the absorbing compound. By monitoring the laser power and the intensity of the sound wave, the concentration of the compound under investigation can be determined.

For both systems, calibration of concentrations was performed using certified mixtures. For the PTR-MS system we used range of dilutions of a mixture containing 600 ppbv of methanol, 800 ppbv of acetaldehyde, 900 ppbv of acetone and 1000 ppbv of isoprene, benzene, toluene and styrene in nitrogen. For the photoacoustic system the same procedure was used with a mixture containing 1 ppmv of ethylene in air.

2.2. Tedlar bags

We used 1.0 l black-layered Tedlar bags (SKC Limited, UK), especially designed for single-breath sampling experiments. The inner bag is made of a clear thin film of Tedlar and is covered by an outer layer of black Tedlar. This outer layer is blackened by adding carbon to the film to avoid UV-induced breakdown of any of the compounds possibly contained in the bag. Every bag has two Teflon hose/valve septum fittings, which simplifies the automated analysis and cleaning of the bags before re-use.

2.3. Experiments

All bags were flushed with synthetic air (mixture of purified nitrogen and $20 \pm 1\%$ purified oxygen; <3 ppm H_2O , <0.5 ppm C_nH_m ; Air Liquide BV, Eindhoven, The Netherlands) with a flow of ~ 25 l h^{-1} for more than 2 h before use. Tedlar bags were filled with various mixtures of air using mass flow controllers (Brooks Instruments, 850S) to compare the composition of the contents at several points in time within a period of 10 days. Since the drift tube of the PTR-MS is operated at a pressure of around 2.25 mbar, no flow controllers or pumps were needed to measure contents of the bags. The sampling lines to and from the bags as well as the in-stream PTR-MS inlet were made of Teflon (PTFE and PFA, Polyfluor Plastics, The Netherlands) to minimize losses due to sticking of compounds to the walls. The calibrated mixture through the flow controller is kept constant at 0.2 l h^{-1} at all times, so equilibrium situation is guaranteed and no losses occur here either.

We investigated whether any artefacts (increase of concentrations of known or unknown compounds) could be observed and whether there were losses to or through the bag wall. The influence of humidity on the stability of the contents was tested by varying the humidity of the sampled mixtures. Some bags were heated ($T \sim 60$ °C) to see if the temperature had an effect on the concentrations found from the bag contents.

2.3.1. Pollution of contents. A total of eight bags were filled with pure nitrogen (4.5 purity level) or synthetic air. These gas mixtures contained no detectable concentrations of hydrocarbons (at the (sub-) ppbv level) before filling. The contents of these bags were monitored to check for increase in concentrations from polluting compounds, either by

permeation through the walls of the bags, or by production from the bag material. These and all other measurements were performed at laboratory temperature, which is controlled at 22 °C, unless stated otherwise. Bags were always stored at lab temperature.

2.3.2. Loss of contents. The stability of a controlled mixing ratio of hydrocarbons was checked by filling 12 bags with a certified mixture (600 ppbv of methanol, 800 ppbv of acetaldehyde, 900 ppbv of acetone, 1000 ppbv of isoprene, benzene, toluene and styrene, Scott Specialty Gases, USA), diluted to a mixing ratio of 1 in 5 with nitrogen.

Also, a total of 24 bags were filled with the breath of 9 healthy volunteers. The contents of 10 of these bags were monitored 6 times in a period of 250 h; the other 14 bags were analysed 5 times within 72 h. It should be noted that condensation of water contained in the exhaled breath occurs in the sampling device before the bag, so no water droplets are formed inside the bag.

To test the suitability of these Tedlar bags for ethylene, 3 bags were filled with room air, containing low amounts of ethylene (below 1 ppbv), another 3 bags were filled with breath and 3 bags were filled with varying higher amounts of ethylene (65–100 ppbv). The concentrations in the bags at 1 h after filling were compared to the concentrations at 72 h after filling.

Possible losses could occur due to permeation through the walls or due to adhesion to the walls. To test whether compounds permeate through the wall, three bags were filled with a calibrated mixture (containing methanol at 600 ppbv, acetaldehyde at 800 ppbv, acetone at 900 ppbv and isoprene, benzene, toluene and styrene at 1000 ppbv). These bags were placed in a larger glass cuvette. The glass cuvette was flushed with nitrogen (4.5 purity level) gas for 10 min via an inlet and outlet before sealing, to make sure that no detectable hydrocarbon levels surrounded the bags at the moment the experiment started. After 2, 3 and 7 days, the contents of the glass cuvette were measured by PTR-MS and compared to nitrogen values and lab air values. After 7 days the contents of the bags were also analysed.

2.3.3. Relative humidity. Relative humidity was increased to 80% for 6 of the 12 bags by mixing the calibrated mixture with humidified (100% RH) nitrogen gas. The latter was done by bubbling the nitrogen gas through a water reservoir, resulting in a RH of 80% for the calibrated mixture. These experiments were performed to see if the water vapour in the bag affects the lifetime of compounds inside. The relative humidity is monitored by PTR-MS via the amount of cluster formation at mass 37 amu, where the water clusters $\text{H}_3\text{O}^+ \cdot \text{H}_2\text{O}$ can be observed.

All bags were measured several times over a prolonged period of time. Due to the limited volume of the bag (1 litre), we could only sample 5 or 6 times. Each time the bag contents were analysed, 8 mass scans from 20 amu to 150 amu were made (1 amu s⁻¹ scan rate) and averaged. The bags were stored and measured at laboratory temperature, which is set to 22 °C.

3. Results and discussion

3.1. Pollution of contents

Several bags were filled with clean air or pure nitrogen. These bags displayed significant amounts of pollution. Figure 2 (left panel) shows pollution reflected by characteristic ions at masses 88 and 95 amu where significant increases were found. Every single bag used in this study showed an increase of these two masses. The compound found at mass 88 is most

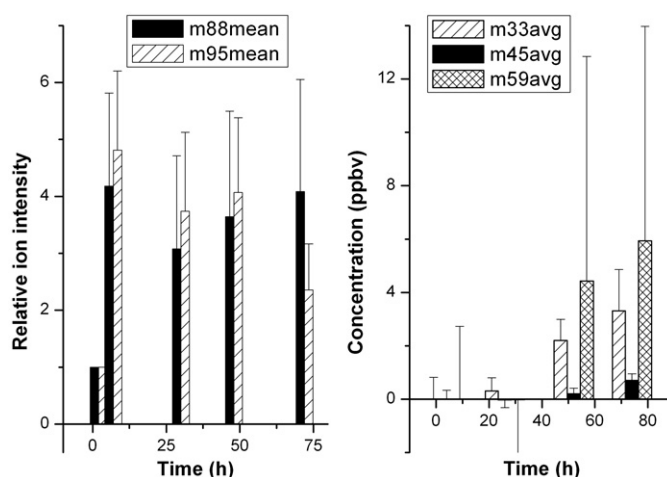

Figure 2. Pollution of synthetic air and nitrogen gas (4.5 purity). Left panel: increase in masses 88 and 95 due to pollution from the Tedlar material (background values are zero). The large error bars are caused by large differences in amounts of pollution coming from the respective bags. Right panel: increase in masses 33, 45 and 59 (corresponding to expected compounds methanol, acetaldehyde and acetone, respectively) concentrations (background values subtracted). The large errors are caused by the low concentrations of the compounds measured and the variation between different bags.

probably *N,N*-dimethylacetamide (C_4H_9NO , $MW = 87$ amu, $PA\ 217.0\ kcal\ mol^{-1}$) and was found to originate from the Tedlar film (Chase 2001, Du Pont 1964). The Tedlar bag is made out of polyvinyl fluoride film, which is produced from polyvinyl fluoride powder, which is dissolved in a ‘latent solvent’ at temperatures above $100\ ^\circ C$, so the particles are allowed to coalesce into a film before the solvent evaporates (Chase 2001). Several candidates for this latent solvent are listed, among which are *N,N*-dimethylacetamide and related compounds (Du Pont 1964). After the drying process the total amount of latent solvent left in the material is assured to be less than 0.5% (Du Pont 1964). The concentrations of *N,N*-dimethylacetamide ranged from 40 to 185 ppbv (this is a lower limit, calculated using $k = 2 \times 10^{-9}\ cm^2\ s$, assuming no fragmentation) at mass 88 after 4 h and increased in time. Clean air and nitrogen contained no measurable quantities of *N,N*-dimethylacetamide (<0.5 ppbv). The manufacturer of the bags assured that besides *N,N*-dimethylacetamide, no other solvent or chemical was used to make the bags. Our results, however, show that a second pollutant is present at mass 95. Independent GC-MS analysis has identified the compound at mass 88 amu to be indeed *N,N*-dimethylacetamide and the compound at mass 95 amu to be phenol (Amann, private communication, Di Francesco, private communication). Heating of the bags increased the signals on both mass 88 and 95 amu significantly ($\sim 170\%$ and 90% respectively, results not shown).

See endnote 1

Some other masses also show a slight increase in ion intensity. This much lower degree of pollution was only observed for those bags containing synthetic air or nitrogen (figure 2, right panel). Mass 59 was found to be increased to about 5 ppbv after 250 h. It should be noted that these values are still less than 10% of the values expected in human breath and the influence will therefore be within the system’s uncertainty of the determination of breath concentrations.

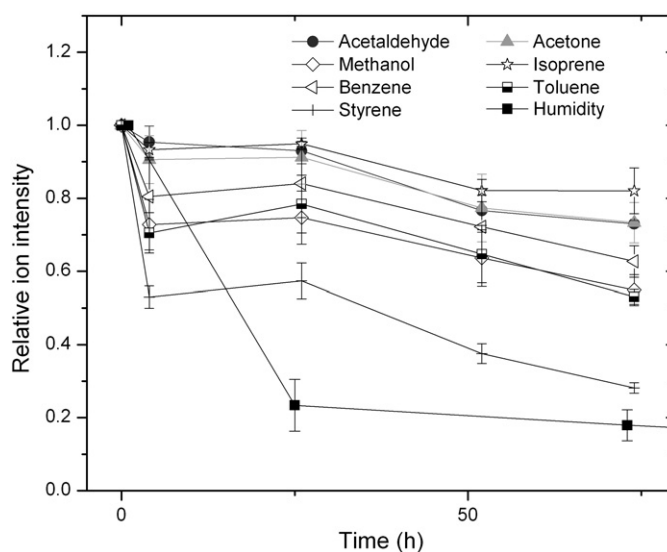

Figure 3. Relative decreases in signals for seven different gases and relative humidity as a function of time. Values are normalized to the signals found in the sample flow immediately before filling. Humidity is monitored by the number of water clusters $\text{H}_3\text{O}^+ \cdot \text{H}_2\text{O}$ at mass 37 amu. All values are normalized to values at $t = 0$ h.

3.2. Loss of contents

Losses of compounds contained in a Tedlar bag were monitored by sampling controlled amounts of calibrated mixture and breath. Figure 3 shows the evolution of the concentrations of the various compounds from the calibrated mixture. The values at 0 h are the mixed flows used to fill the bags.

There is a considerable loss ranging from 5% up to 47% at 4 h after filling. We consider these losses to occur during filling, presumably due to sticking to the septum in the inlet valves, since over time we find only a gradual decrease with respect to those values measured after 4 h. From the seven compounds, styrene is the only compound found to decrease for more than 15% ($30 \pm 7\%$) between 4 h and 52 h. From the decline of their concentration between 4 h and 72 h after gas sampling, a half-life for the respective compounds can be calculated. These half-lives are 8.1 ± 0.6 days for methanol, 6.5 ± 0.3 days for acetaldehyde, 8.4 ± 0.6 days for acetone, 13 ± 0.8 days for isoprene, 8.2 ± 0.8 days for benzene, 8.4 ± 0.7 days for toluene and 5.9 ± 0.3 days for styrene.

Other authors (cf Sulyok (2001)) have found lower recovery rates in black-layered Tedlar bags, as compared with clear Tedlar bags. In this study we aimed at characterizing black-layered bags and no attempt was made to compare both black-layered and clear Tedlar bags.

Low ethylene levels in the bags displayed no measurable decrease over 3 days. These bags include the ones filled with breath, where ethylene levels are usually around 1 ppbv. Higher ethylene concentrations in the bags decreased with less than 5% after 3 days.

Water vapour content decreases drastically by 80% within about 24 h (figure 3) and is then only slowly reduced to about 12.5% of its initial value after 250 h. Heating the bag does not regain this loss of water. This establishes the findings of Groves and co-workers (Groves and Zellers 1996), who suggest water to permeate through the walls of the bag.

In bags filled with breath, the decrease of sampled gas concentrations in time was found to be somewhat lower (table 1). From breath (tentatively identified) methanol, acetaldehyde,

Table 1. Relative average ion intensity values found at several masses from the breath of ten volunteers at different time points. The data at 2 h indicate average (\pm sd) count rates, where the values at later time points are expressed in percentages of the values at 2 h. *P*-value indicates the significance of a change in ion intensity between 2 h and 240 h. The spread in the 2 h values indicates the inter-personal variation in the concentration of the compounds.

Mass (compound ^a) (amu)	2 h signal intensity (ncps \pm sd)	24 h (% \pm %)	72 h (% \pm %)	144 h (% \pm %)	240 h (% \pm %)	<i>P</i> value of change ^b
31	14 \pm 10	2.6 \times 10 ² \pm 1.3 \times 10 ²	2.2 \times 10 ² \pm 1.8 \times 10 ²	2.3 \times 10 ² \pm 1.6 \times 10 ²	1.8 \times 10 ² \pm 1.4 \times 10 ²	0.144
33 (methanol)	2.7 \times 10 ³ \pm 1.2 \times 10 ³	1.1 \times 10 ² \pm 0.2 \times 10 ²	0.9 \times 10 ² \pm 0.4 \times 10 ²	0.7 \times 10 ² \pm 0.1 \times 10 ²	0.4 \times 10 ² \pm 0.1 \times 10 ²	0.001 ^b
41	87 \pm 50	3.7 \times 10 ² \pm 3 \times 10 ²	3.6 \times 10 ² \pm 2.8 \times 10 ²	4 \times 10 ² \pm 2.4 \times 10 ²	4.6 \times 10 ² \pm 3.4 \times 10 ²	0.001 ^b
43	2.8 \times 10 ² \pm 1.1 \times 10 ²	1.2 \times 10 ² \pm 0.3 \times 10 ²	1.7 \times 10 ² \pm 1 \times 10 ²	1.9 \times 10 ² \pm 0.7 \times 10 ²	1.8 \times 10 ² \pm 0.8 \times 10 ²	0.019 ^b
45 (acetaldehyde)	3.4 \times 10 ² \pm 2 \times 10 ²	1.2 \times 10 ² \pm 0.3 \times 10 ²	1.7 \times 10 ² \pm 1.4 \times 10 ²	1.5 \times 10 ² \pm 0.5 \times 10 ²	1 \times 10 ² \pm 0.4 \times 10 ²	0.726
47 (ethanol)	1.6 \times 10 ² \pm 0.6 \times 10 ²	1.2 \times 10 ² \pm 0.4 \times 10 ²	0.9 \times 10 ² \pm 0.4 \times 10 ²	1 \times 10 ² \pm 0.5 \times 10 ²	0.8 \times 10 ² \pm 0.6 \times 10 ²	0.072 ^b
59 (acetone)	3.7 \times 10 ³ \pm 1.5 \times 10 ³	1.3 \times 10 ² \pm 0.2 \times 10 ²	1 \times 10 ² \pm 0.4 \times 10 ²	1.4 \pm 0.9 \times 10 ²	1 \times 10 ² \pm 0.5 \times 10 ²	0.851
61	1.7 \times 10 ² \pm 0.6 \times 10 ²	0.9 \times 10 ² \pm 0.4 \times 10 ²	1.2 \times 10 ² \pm 0.6 \times 10 ²	1.1 \times 10 ² \pm 0.6 \times 10 ²	1.3 \times 10 ² \pm 0.5 \times 10 ²	0.450
63	45 \pm 23	4.2 \times 10 ² \pm 3.7 \times 10 ²	3.8 \times 10 ² \pm 3.1 \times 10 ²	3.6 \times 10 ² \pm 2.4 \times 10 ²	2.6 \times 10 ² \pm 1.4 \times 10 ²	0.0018
69 (isoprene)	4.6 \times 10 ² \pm 1.1 \times 10 ²	1.2 \times 10 ² \pm 0.3 \times 10 ²	1.2 \times 10 ² \pm 0.4 \times 10 ²	1.3 \times 10 ² \pm 0.4 \times 10 ²	0.9 \times 10 ² \pm 0.3 \times 10 ²	0.380
71	60 \pm 61	1 \times 10 ² \pm 0.9 \times 10 ²	1.2 \pm 0.7 \times 10 ²	1.8 \times 10 ² \pm 1.6 \times 10 ²	2 \times 10 ² \pm 16 \times 10 ²	0.925
88 (<i>N,N</i> -dimethylacetamide)	6.8 \times 10 ² \pm 2 \times 10 ²	0.8 \times 10 ² \pm 0.4 \times 10 ²	2.5 \times 10 ² \pm 1.6 \times 10 ²	1.1 \times 10 ² \pm 0.6 \times 10 ²	2.9 \times 10 ² \pm 2 \times 10 ²	0.007 ^b
93	22 \pm 14	0.6 \times 10 ² \pm 0.8 \times 10 ²	0.6 \times 10 ² \pm 0.9 \times 10 ²	1.2 \times 10 ² \pm 1 \times 10 ²	1.5 \times 10 ² \pm 1.3 \times 10 ²	0.410
95	2.5 \times 10 ² \pm 0.8 \times 10 ²	1.3 \times 10 ² \pm 0.5 \times 10 ²	2.9 \times 10 ² \pm 1.6 \times 10 ²	2.1 \times 10 ² \pm 0.7 \times 10 ²	3.3 \times 10 ² \pm 1.7 \times 10 ²	0.000 ^b

^a Identification is tentative.

^b *P* value of student's *t*-test for equality of means.

* *P* values smaller than 0.1 are considered significant.

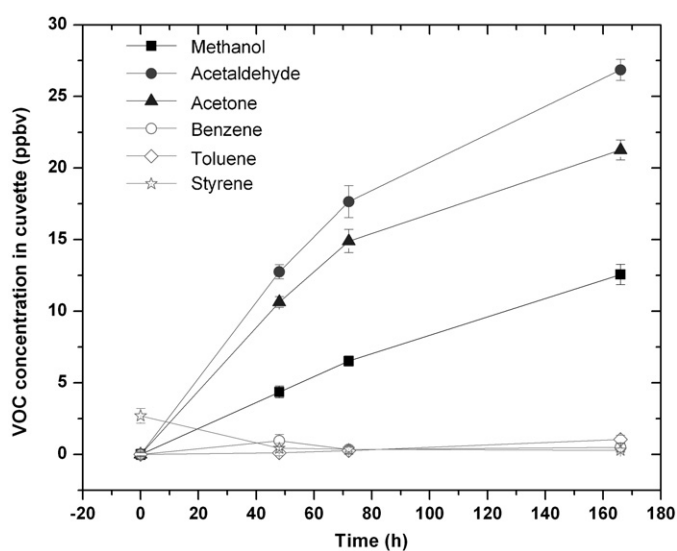

Figure 4. Concentrations of six different compounds in the glass cuvette enclosing three Tedlar bags filled with calibrated mixture. As the concentrations of compounds in the bags decrease (see figure 3), a corresponding increase is found in the surrounding airspace in the cuvette. Temperature was the same for all time points (22 °C).

acetone and isoprene can be compared with the certified mixture measurements. Of these four compounds, only methanol is found to decrease significantly. Besides methanol, only ethanol is found to also decrease significantly. On the other hand masses 41, 88, 95 increase significantly. Deviations from the average values are increasing over time.

Heating of the bags resulted in an increase of several compounds, although the effect for most compounds was in the range of 2–10% of the value for the unheated bag. This indicates that only a small proportion of the volatile contents is adsorbed to the wall and that most of it probably diffused through. Masses 88 and 95, which are due to the bag material itself, displayed an increase of about 170% and 88% with respect to the values of the unheated bag.

A separate experiment was performed to test the diffusion through the bag wall. Figure 4 shows the concentrations of six compounds in the glass cuvette enclosing three Tedlar bags on four different moments. Methanol, acetaldehyde and acetone clearly increase over time, whereas benzene and toluene show no significant increase. The gain in concentration in the cuvette corresponds well with the decreases found from the bags for acetaldehyde and acetone (within measurement uncertainty). For methanol, only 20% of the losses from the bag content are found back in the cuvette. As can be seen from the trends in figure 4 the loss rate decreases when the difference in concentration between the inside and outside of the bags decreases, which can be expected from a diffusion phenomenon.

3.3. Relative humidity

The influence of relative humidity on the concentrations in a bag was tested by increasing the relative humidity to at least 80% (100% for bags containing air or nitrogen, 80% for bags containing calibrated mixture). There was no observable effect of water vapour on the stability of the bag contents. No significant differences could be found between ‘dry’ (RH = ‘0’%) and ‘wet’ air (RH > 80%) (results not shown).

4. Conclusion

We have tested the suitability of black-layered Tedlar bags for breath sampling. The contents of the bags were found to be polluted, by two compounds giving rise to characteristic ions at masses 88 and 95 amu, identified by three independent groups as *N,N*-dimethylacetamide and phenol, respectively (Amann, private communication; Di Francesco, private communication). It should be kept in mind that these products are present in significant quantities when analysing the volatile content of the bags. The ion intensities and the variation therein essentially make them 'blind spots' in PTR-MS analysis of the bag contents, since the amount of pollution varies greatly from one bag to another.

Compounds from the standard gas mixture are found to display considerable and reproducible losses between 5 and 50% during filling. The losses possibly occur due to sticking effects on the septum in the fitting. After this drastic decrease during filling, all compounds except styrene show only a slow decrease in concentration, ranging from ~10% within 2 days for isoprene to ~25% for styrene, which shows by far the fastest decrease of all compounds tested (see figure 3). The compounds in the test mixture represent most chemical groups of volatile organic compounds usually found in breath (Amann 2005). An important other chemical group, sulphur compounds, has been investigated in more detail elsewhere (Nielsen 2002). The pure compounds tested here all display a half-life of ~6 days or longer.

Immediate losses during filling can also be expected for breath VOCs, although these have not been tested here. Most of the losses during storage from compounds in breath were limited to less than 10% within 52 h. These observed decreases from VOCs in breath samples (compared are methanol, acetaldehyde, acetone and isoprene) are lower than the decreases measured for the compounds in the standard gas mixtures. This might be due to the relatively high concentrations (200 ppbv or higher) from the pure compounds in comparison to most values commonly found in breath. Diffusion, which we showed to be a loss mechanism, depends on the concentration gradient, decreasing the losses with decreasing differences in concentration between the inside of the bag and the environment around it.

Relative humidity showed not to have a significant effect on the lifetime of compounds in the bags. Groves and co-workers (Groves and Zellers 1996) did find a significant influence for methanol and acetone, but only at supersaturated humidity levels.

Even though two compounds are demonstrated to pollute the contents of the bags, these will not interfere with the analysis of other compounds contained in them. After immediate losses during filling, only slow and reproducible (comparable for all bags measured in two series of measurements) decreases in concentrations are observed. The variations in these losses are generally smaller than the inter-personal differences for most compounds present in breath (for these variations, see, for instance, Turner *et al* (2006a, 2006b, 2006c, 2006d)). To increase reproducibility, we advise a fixed point in time after sampling is chosen for the analysis of the contents. We conclude that, as long as the bags are characterized for the compounds measured in such a study and a fixed time point after collection is chosen, black-layered Tedlar bags are suitable to be used for sampling breath in clinical studies, where it is not possible to analyse the breath sample immediately.

Acknowledgments

The authors would like to thank Professor Norman Ratcliffe from the University of West England, Professor Anton Amann, University of Innsbruck, Professor Fabio di Francesco,

University of Pisa who kindly and independently confirmed us from their GC-MS data, the identification of both *N,N*-dimethylacetamide and phenol.

References

- Amann A 2005 Breath analysis for medical diagnosis and therapeutic monitoring *Spectrosc. Eur.* **17** 18
- Berkelmans H W A, Moeskops B W M, Bominaar J, Scheepers P T J and Harren F J M 2003 Pharmacokinetics of ethylene in man by on-line laser photoacoustic detection *Toxicol. Appl. Pharmacol.* **190** 206–13
- Boamfa E, Steeghs M, Cristescu S and Harren F 2004 Trace gas detection from fermentation processes in apples: an intercomparison study between proton-transfer-reaction mass spectrometry and laser photoacoustics *Int. J. Mass Spectrom.* **239** 193–201
- Boschetti A *et al* 1999 PTR-MS real time monitoring of the emission of volatile organic compounds during postharvest aging of berryfruit *Postharvest Biol. Technol.* **17** 143–51
- Chase R E 2001 Properties and manufacture of Tedlar Polyvinyl fluoride film *ERC Technical Report* VERL, Ford Research Laboratory, May 1st, 2001
- Critchley A, Elliott T, Harrison G, Mayhew C, Thompson J and Worthington T 2004 The proton transfer reaction mass spectrometer and its use in medical science: applications to drug assays and the monitoring of bacteria *Int. J. Mass Spectrom.* **239** 235–41
- Dannecker J, Shaskan E and Phillips M 1981 A new highly sensitive assay for breath acetaldehyde detection of endogenous levels in humans *Anal. Biochem.* **114** 1–7
- Davies S, Spanel P and Smith D 2001 A new 'online' method to measure increased exhaled isoprene in end-stage renal failure *Nephrol. Dial. Transpl.* **16** 836–9
- de Gouw J, Warneke C, Karl T, Eerdekens G, van der Veen C and Fall R 2003 Sensitivity and specificity of atmospheric trace gas detection by proton-transfer-reaction mass spectrometry *Int. J. Mass Spectrom.* **223–224** 382
- Deng 2004 Determination of acetone in human breath by gas chromatography-mass spectrometry and solid-phase microextraction with on-fiber derivatization *J. Chromatogr. B* **810** 269–75 See endnote 2
- Co du Pont E I 1964 Process of preparing oriented, organic thermoplastic polymeric film Patent nr. 3.138.470, United States Patent Office
- Groves W and Zellers E 1996 Investigation of organic vapor losses to condensed water vapor in Tedlar bags used for exhaled-breath sampling *Am. Ind. Hyg. Assoc. J.* **57** 257–63
- Harren F J M, Berkelmans R, Kuiper K, Hekker S T L, Scheepers P, Dekhuijzen R, Hollander P and Parker D H 1999 On-line laser photoacoustic detection of ethene in exhaled air as biomarker of ultraviolet radiation damage of the human skin *Appl. Phys. Lett.* **74** See endnote 3
- Harren F J M and Reuss J 1997 *Photoacoustic Spectroscopy* vol 19, ed G L Trigg (New York: Wiley) (*Encycl. Appl. Phys.*) pp 413–35
- Hewitt C, Hayward S and Tani A 2003 The application of proton transfer reaction-mass spectrometry (PTR-MS) to the monitoring and analysis of volatile organic compounds in the atmosphere *J. Environ. Monit.* **5** 1–7
- Holzinger R, Sandoval-Soto L, Rottenberger S, Crutzen P and Kesselmeier J 2000 Emissions of volatile organic compounds from *Quercus ilex* L. measured by proton transfer reaction mass spectrometry under different environmental conditions *J. Geophys. Res.-Atmos.* **105** 20573–9
<http://webbook.nist.gov/chemistry/>
- Hyspler 2000 Determination of isoprene in human expired breath using solid-phase microextraction and gas chromatography-mass spectrometry *J. Chromatogr. B* **739** 183–90
- Jobson B 2005 On-line analysis of organic compounds in diesel exhaust using a proton transfer reaction mass spectrometer (PTR-MS) *Int. J. Mass Spectrom.* **245** 77–88
- Jordan A, Hansel A, Holzinger R and Lindinger W 1995 Acetonitrile and benzene in the breath of smokers and nonsmokers investigated by proton-transfer reaction mass spectrometry (PTR-MS) *Int. J. Mass Spectrom. Ion Process.* **148** L1–3
- Karl T, Prazeller P, Mayr D, Jordan A, Rieder J, Fall R and Lindinger W 2001 Human breath isoprene and its relation to blood cholesterol levels: new measurements and modeling *J. Appl. Phys.* **91** 762–70
- Kneepkens C M F, Lepage G and Roy C C 1994 The potential of the hydrocarbon breath test as a measure of lipid peroxidation *Free Radic. Biol. Med.* **17** 127–60
- Lau Y K 1989 Measurement of sulphur gases in ambient air *Environ. Monit. Assess.* **13** 69–74
- Lechner M, Colvin H P, Ginzler C, Lirk P, Rieder J and Tilg H 2005 Headspace screening of fluid obtained from the gut during colonoscopy and breath analysis by proton transfer reaction-mass spectrometry: a novel approach in the diagnosis of gastro-intestinal diseases *Int. J. Mass Spectrom.* **243** 151–4
- Lindinger C 2005 Unambiguous identification of volatile organic compounds by proton-transfer reaction mass spectrometry coupled with GC/MS *Anal. Chem.* **77** 4117–24

- Lindinger W, Hansel A and Jordan A 1998a Proton-transfer-reaction mass spectrometry (PTR-MS): on-line monitoring of volatile organic compounds at pptv levels *Chem. Soc. Rev.* **27** 347–54
- Lindinger W, Hansel A and Jordan A 1998b On-line monitoring of volatile organic compounds at pptv levels by means of proton-transfer-reaction mass spectrometry (PTR-MS)—medical applications, food control and environmental research *Int. J. Mass Spectrom.* **173** 191–241
- Myung 1997 Gas chromatographic-mass spectrometric analysis of mercaptan odorants in liquefied petroleum gas and liquefied natural gas *J. Chromatogr. A* **791** 367–70
- Nielsen 2002 Quantification of volatile sulfur compounds in complex gaseous matrices by solid-phase microextraction *J. Chromatogr. A* **963** 57–64
- Phillips M 1992 Breath tests in medicine *Sci. Am.* **267** 74–9
- Phillips M *et al* 1999 Breath markers of heart transplant rejection *Circulation* **100** 525–5
- Phillips M and Greenberg J 1991 Method for the collection and analysis of volatile compounds in the breath *J. Chromatogr. Biomed. Appl.* **564** 242–9
- Prazeller P, Karl T, Jordan A, Holzinger R, Hansel A and Lindinger W 1998 Quantification of passive smoking using proton-transfer reaction mass spectrometry *Int. J. Mass Spectrom.* **178** **See endnote 4**
- Steeghs M, Bais H, de Gouw J, Goldan P, Kuster W, Northway M, Fall R and Vivanco J 2004 Proton-transfer-reaction mass spectrometry as a new tool for real time analysis of root-secreted volatile organic compounds in arabidopsis *Plant Phys.* **135** 47–58
- Steeghs M M L, Moeskops B W M, van Swam K, Cristescu S M, Scheepers P T J and Harren F J M 2006 On-line monitoring of UV-induced lipid peroxidation products from human skin in vivo using Proton-Transfer Reaction Mass Spectrometry *Int. J. Mass Spectrom.* **253** 58–64
- Sulyok 2001 Investigation of the storage stability of selected volatile sulfur compounds in different sampling containers *J. Chromatogr. A* **917** 367–74
- Turner C, Spanel P and Smith D 2006a A longitudinal study of breath isoprene in healthy volunteers using selected ion flow tube mass spectrometry (SIFT-MS) *Phys. Meas.* **27** 13–22
- Turner C, Spanel P and Smith D 2006b A longitudinal study of ammonia, acetone and propanol in the exhaled breath of 30 subjects using selected ion flow tube mass spectrometry, SIFT-MS *Phys. Meas.* **27** 321–37
- Turner C, Spanel P and Smith D 2006c A longitudinal study of methanol in the exhaled breath of 30 healthy volunteers using selected ion flow tube mass spectrometry, SIFT-MS *Phys. Meas.* **27** 637–48
- Turner C, Spanel P and Smith D 2006d A longitudinal study of ethanol and acetaldehyde in the exhaled breath of 30 subjects using selected ion flow tube mass spectrometry, SIFT-MS *Rapid Commun. Mass Spectrom.* **20** 61–8
- Wang T, Spanel P and Smith D 2004 A selected ion flow tube study of the reactions of H_3O^+ , NO^+ and $\text{O-2}(\text{+center dot})$ with some phenols, phenyl alcohols and cyclic carbonyl compounds in support of SIFT-MS and PTR-MS *Int. J. Mass Spectrom.* **239** 139–46
- Warneke C, Kuczynski J, Hansel A, Jordan A, Vogel W and Lindinger W 1996 Proton transfer reaction mass spectrometry (PTR-MS): propanol in human breath *Int. J. Mass Spectrom. Ion Process.* **154** 61–70
- Werle P 2003 *Diode-Laser Sensors for in-situ Gas Analysis* ed P Hering, J P Lay and S Stry (Berlin: Springer)
- Woltering E, Harren F and Bicanic D D 1989 Laser photo-acoustics, a novel method for ethylene determination in plant physiology studies *Acta Horticultura* 201–8

Endnotes

- (1) Author: Please include references ‘Amann, private communication’ and ‘Di Francesco, private communication’ in the references list.
- (2) Author: Please provide complete names of authors in references Deng (2004), Hyspler (2000), Myung (1997) and Sulyok (2001).
- (3) Author: Please provide page number in reference Harren *et al* (1999).
- (4) Author: Please provide page number in reference Prazeller *et al* (1998).
- (5) Author: Please check whether the sense of the sentence ‘The data at 2 h indicate average’ retains your intended sense in caption of Table 1.
- (6) Author: Please check the value ‘ $1.8 \times 10^2 \pm 0.8 \times 10^2$ ’ in the table as set.

Reference linking to the original articles

References with a volume and page number in blue have a clickable link to the original article created from data deposited by its publisher at CrossRef. Any anomalously unlinked references should be checked for accuracy. Pale purple is used for links to e-prints at arXiv.